



US008385100B2

(12) **United States Patent**
Kau et al.

(10) **Patent No.:** **US 8,385,100 B2**

(45) **Date of Patent:** **Feb. 26, 2013**

(54) **ENERGY-EFFICIENT SET WRITE OF PHASE CHANGE MEMORY WITH SWITCH**

2008/0310211	A1	12/2008	Toda et al.	
2009/0114898	A1	5/2009	Ricker et al.	
2010/0182827	A1*	7/2010	Kostylev et al.	365/163
2010/0214829	A1	8/2010	Breitwisch et al.	
2010/0232205	A1*	9/2010	Parkinson	365/148
2012/0140553	A1	6/2012	Kalb et al.	

(75) Inventors: **Derchang Kau**, Cupertino, CA (US);
Johannes Kalb, San Jose, CA (US);
Elijah Karpov, Santa Clara, CA (US);
Gianpaolo Spadini, Campbell, CA (US)

FOREIGN PATENT DOCUMENTS

(73) Assignee: **Intel Corporation**, Santa Clara, CA (US)

WO	2011001594	6/2011
WO	2011071594	A3 8/2011

OTHER PUBLICATIONS

(*) Notice: Subject to any disclaimer, the term of this patent is extended or adjusted under 35 U.S.C. 154(b) by 90 days.

Ferdinando Bedeschi et al., A Bipolar-Selected Phase Change Memory Featuring Multi-Level Cell Storage, IEEE Journal of Solid-State Circuits, vol. 44, No. 1, Jan. 2009, pp. 217-227.*
International Search Report and Written Opinion received for PCT Patent Application NO. PCT/US2010/052833, mailed on Jul. 1, 2011, 9 pages.
International Preliminary Report and Written Opinion Received for PCT Patent Application No. PCT/US2010/052833, mailed on Jun. 21, 2012, 6 pages.

(21) Appl. No.: **12/653,092**

(22) Filed: **Dec. 8, 2009**

(65) **Prior Publication Data**

US 2011/0134685 A1 Jun. 9, 2011

* cited by examiner

(51) **Int. Cl.**
G11C 11/00 (2006.01)

Primary Examiner — Hoai V Ho

(52) **U.S. Cl.** **365/148**

Assistant Examiner — Pablo Huerta

(58) **Field of Classification Search** 365/148
See application file for complete search history.

(74) *Attorney, Agent, or Firm* — Cool Patent, P.C.; Kenneth J. Cool

(56) **References Cited**

(57) **ABSTRACT**

U.S. PATENT DOCUMENTS

7,135,696	B2	11/2006	Karpov et al.	
7,359,231	B2*	4/2008	Venkataraman et al.	365/148
2006/0073652	A1	4/2006	Pellizzer et al.	
2006/0227592	A1	10/2006	Parkinson et al.	
2007/0041245	A1	2/2007	Ahn	

Embodiments of apparatus and methods for an energy efficient set write of phase change memory with switch are generally described herein. Other embodiments may be described and claimed.

17 Claims, 5 Drawing Sheets

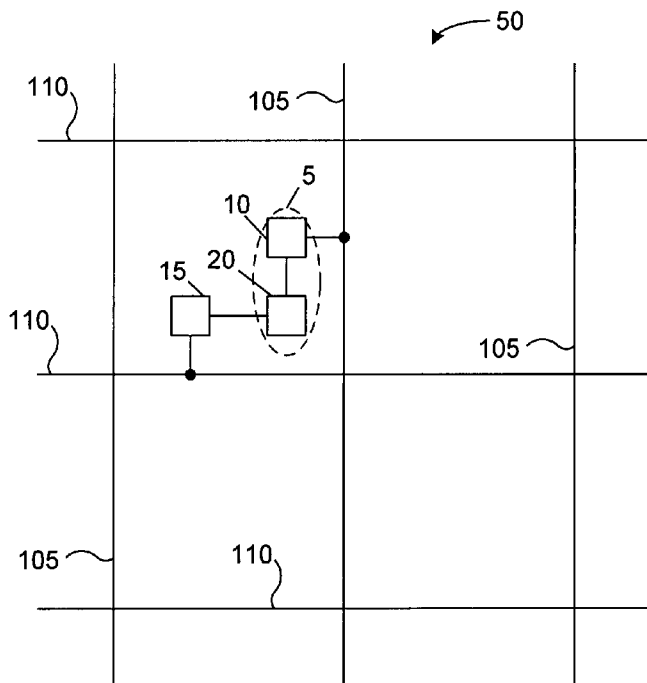

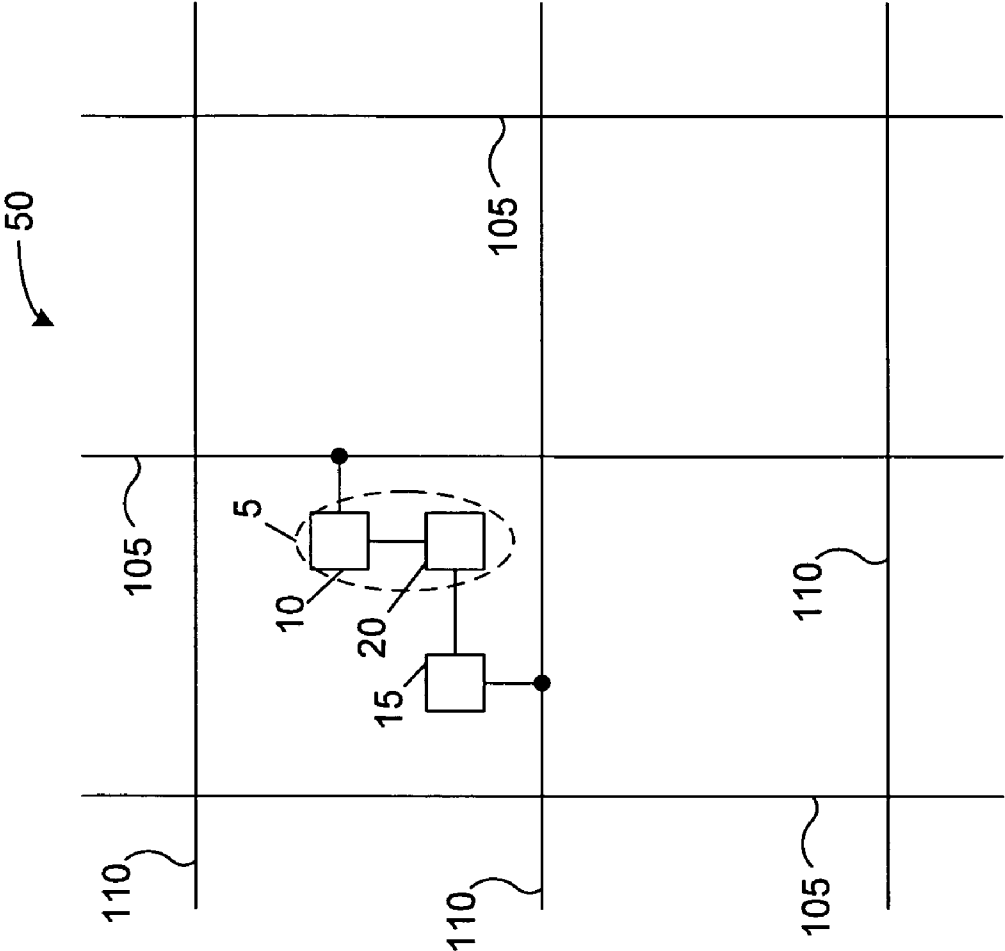

FIG. 1

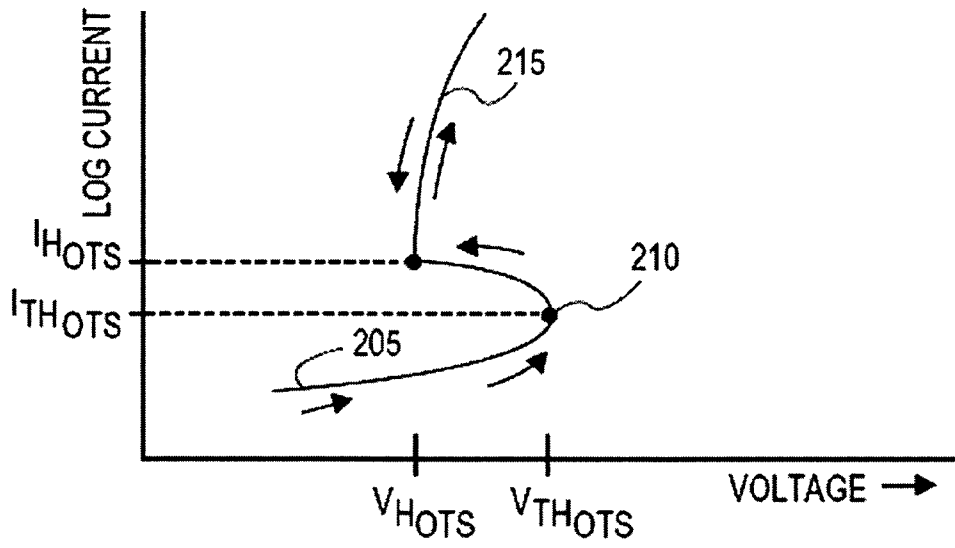

FIG. 2

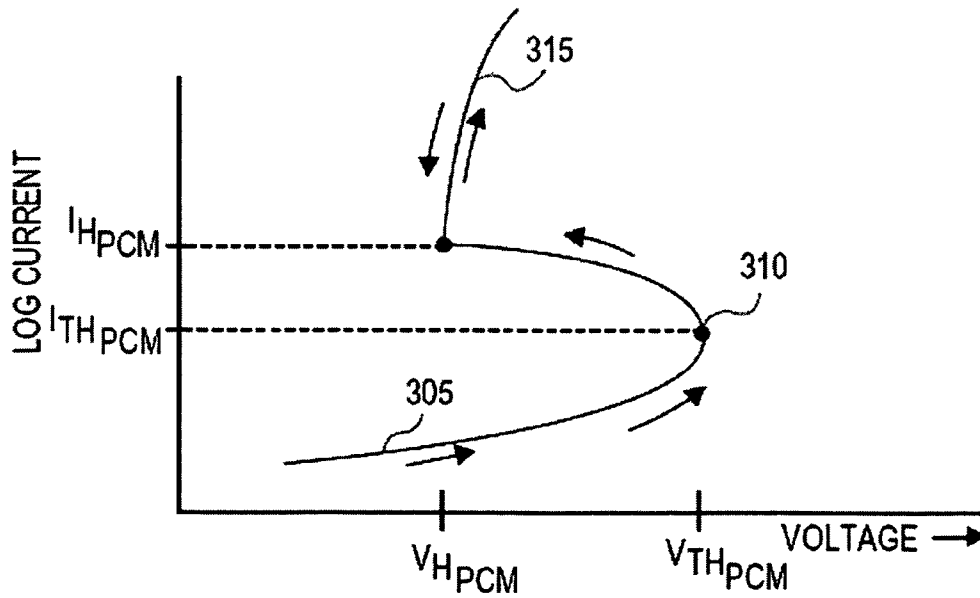

FIG. 3

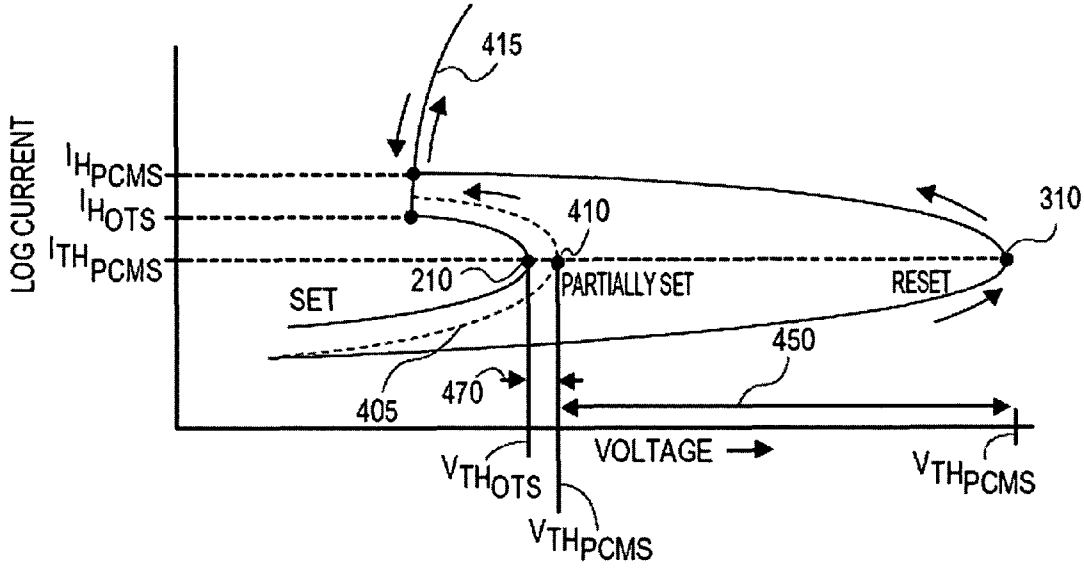

FIG. 4

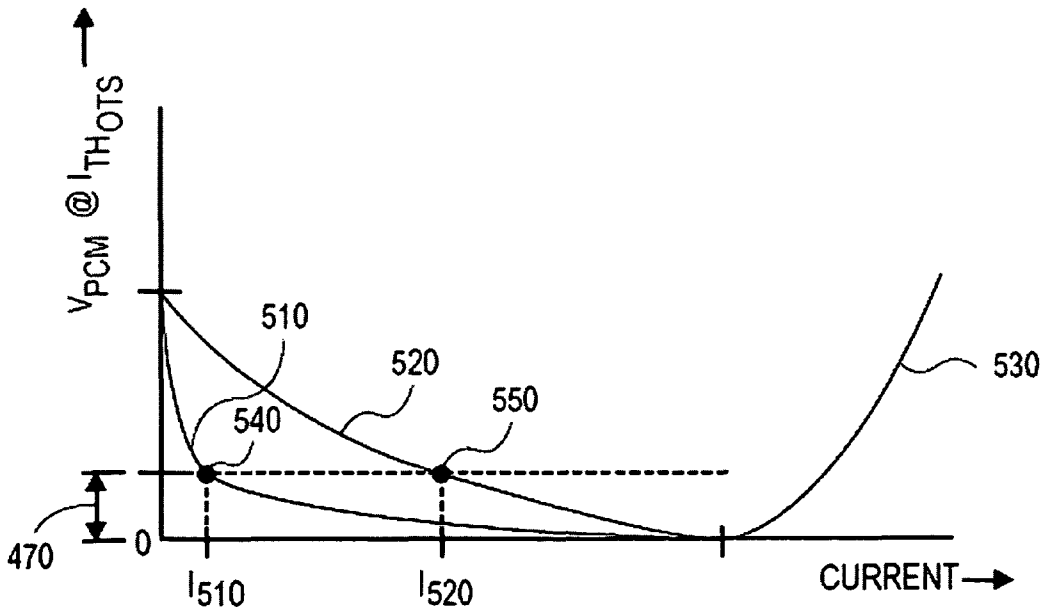

FIG. 5

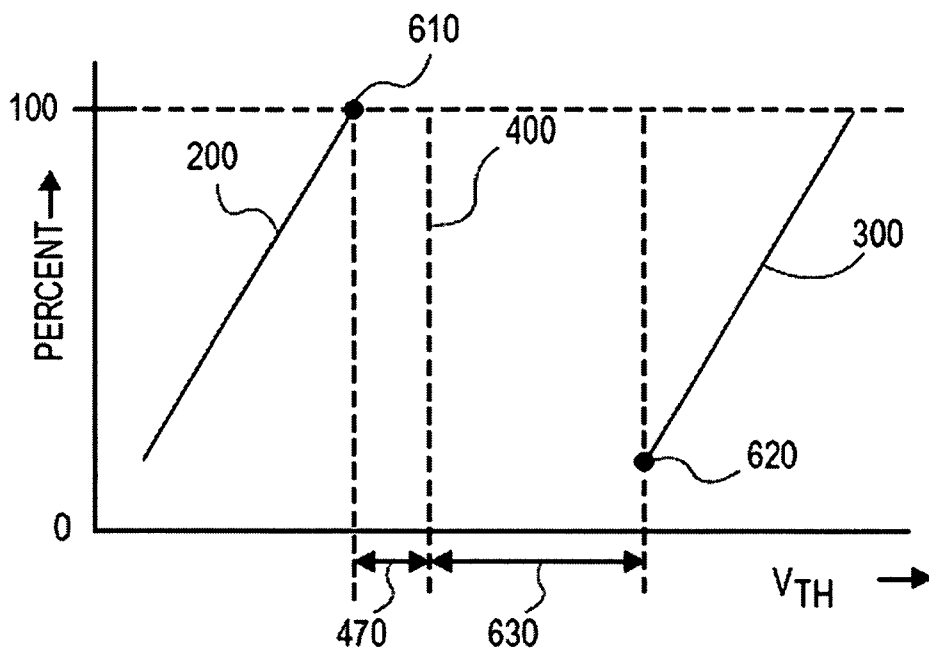

FIG. 6

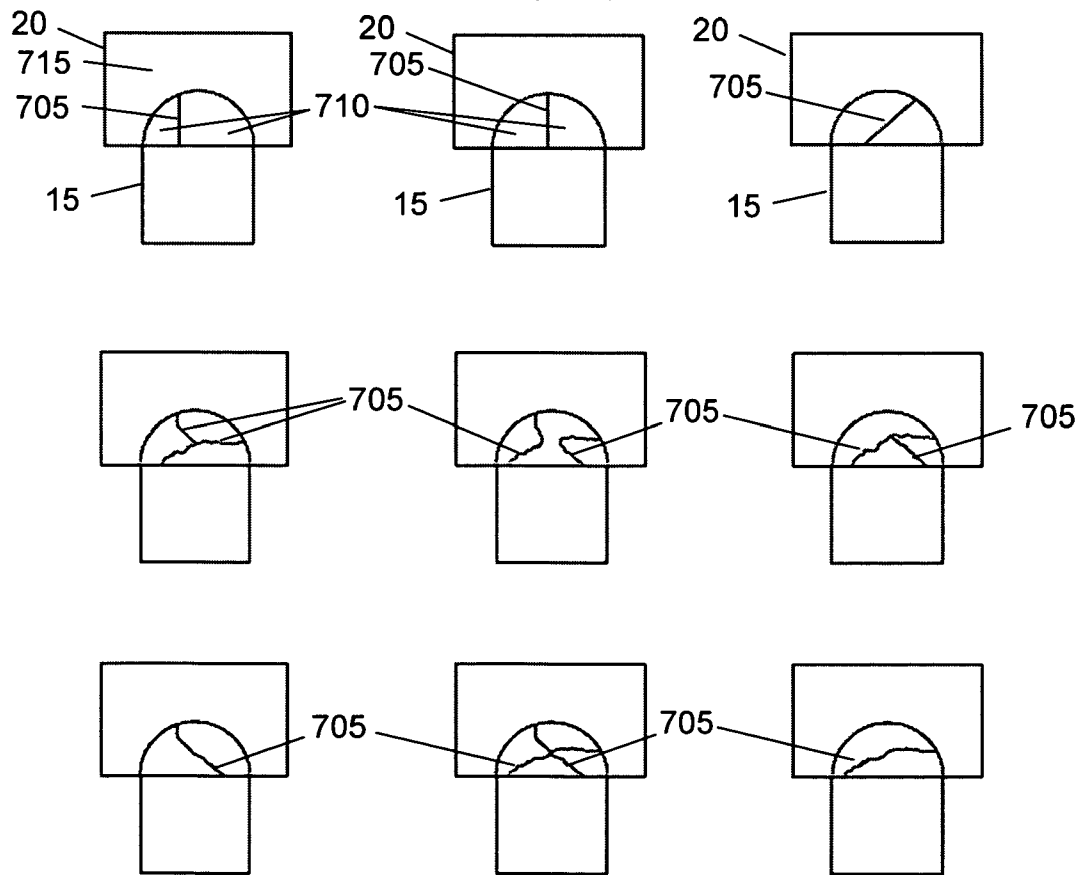

FIG. 7

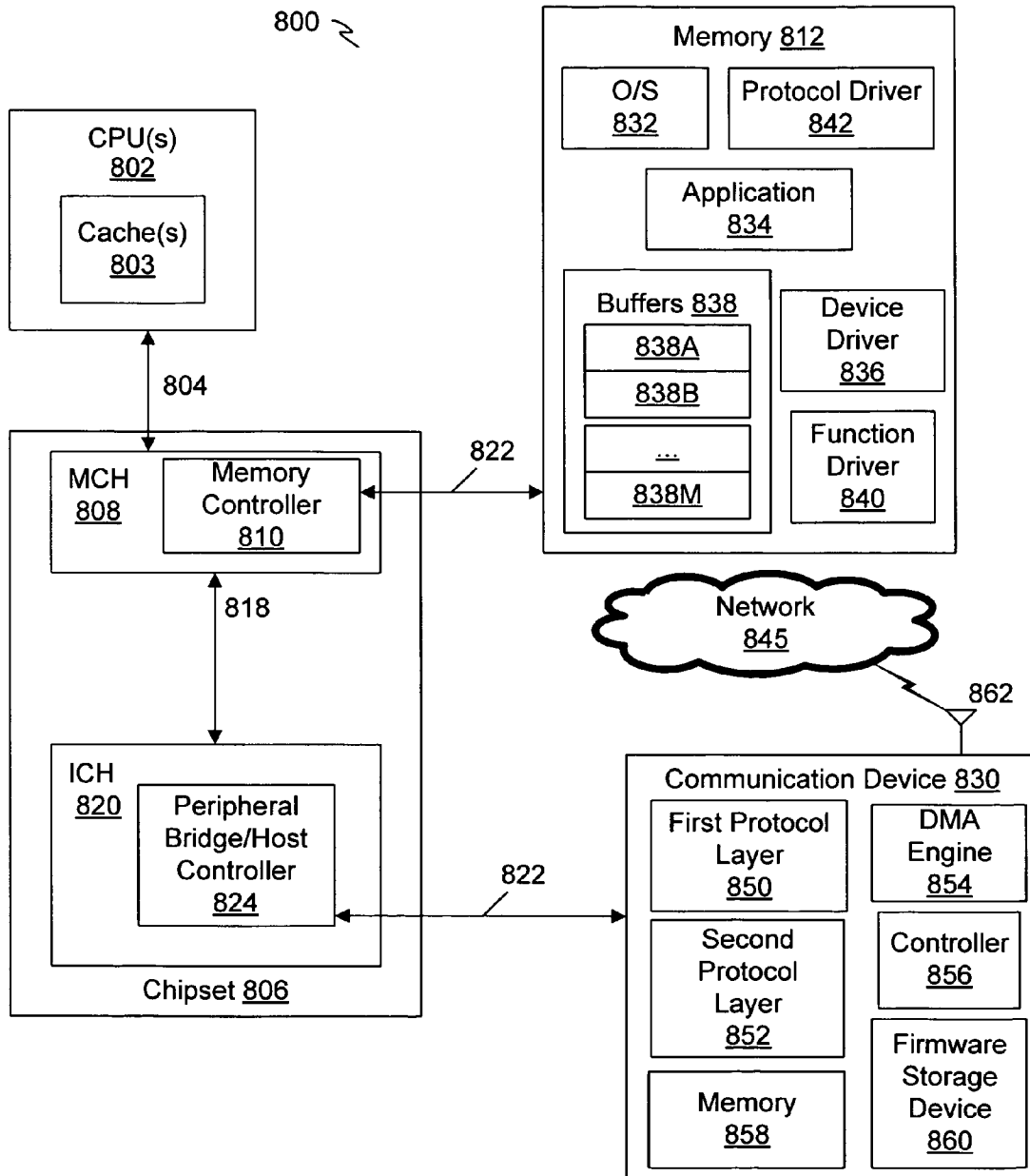

FIG. 8

ENERGY-EFFICIENT SET WRITE OF PHASE CHANGE MEMORY WITH SWITCH

BACKGROUND OF THE INVENTION

1. Field of the Invention

The present invention relates to a field of electronics including semiconductor devices, and more specifically to improving a write SET operation for a phase change memory with switch (PCMS).

2. Discussion of Related Art

Dynamic Random Access Memory (DRAM) and Static Random Access Memory (SRAM) technologies are widely used to store information in electronic systems. However, both DRAM and SRAM are volatile memories that lose stored information whenever electrical power is interrupted. To avoid loss of data and/or code, it is desirable to store certain information in non-volatile memory, especially for portable electronic systems such as mobile internet devices (MID)s or mobile stations.

Flash memory is a type of non-volatile memory. However, despite possessing high density, flash memory is not scalable to very small dimensions since information is stored as charge in a floating gate. A reduction in the number of electrons per bit can ultimately degrade the reliability of stored information.

Phase-change memory with switch (PCMS) is a type of non-volatile memory that is scaleable to extremely small dimensions. A PCMS device may be configured to allow for bit selective erase since every memory cell may be addressed separately by selecting a combination of bit line and word line.

BRIEF DESCRIPTION OF THE DRAWINGS

The subject matter regarded as the invention is particularly pointed out and distinctly claimed in the concluding portion of the specification. The invention, however, both as to organization and method of operation, together with objects, features, and advantages thereof, may best be understood by reference to the following detailed description when read with the accompanying drawings in which:

FIG. 1 shows an array of a phase change memory with switch (PCMS) organized into bit lines and word lines according to an embodiment of the present invention;

FIG. 2 shows a graph of log current vs. voltage for an ovonic threshold switch (OTS) according to an embodiment of the present invention;

FIG. 3 shows a graph of log current vs. voltage for a phase change memory (PCM) in a RESET state according to an embodiment of the present invention;

FIG. 4 shows a graph of log current vs. voltage for a PCMS according to an embodiment of the present invention;

FIG. 5 shows a graph of log voltage vs. current for a PCM according to an embodiment of the present invention;

FIG. 6 shows a cumulative probability plot of threshold voltage for an array of memory cells according to an embodiment of the present invention;

FIG. 7 shows a phase change memory storage element with an amorphous volume having conducting filament(s) according to embodiments of the present invention; and

FIG. 8 shows a block diagram of an electronic device comprising various embodiments of the invention.

DETAILED DESCRIPTION OF THE PRESENT INVENTION

In the following detailed description, numerous specific details for an energy-efficient PCMS are set forth to provide

a thorough understanding of the invention. However, it will be understood by those skilled in the art that the present invention may be practiced without these specific details. In other instances, well-known methods, procedures, components and circuits have not been described in detail so as not to obscure the present invention.

It would be an advance in the art to provide a way to decrease energy consumption for writing of a phase change memory (PCM) storage element. The PCM element may be configured as a combined device comprising a switch, such as an ovonic threshold switch (OTS), to form a PCMS device. A PCMS device may be RESET using only a fraction of the energy typically used to SET the PCMS device with a completely crystallized PCM storage element. The higher energy consumption is due to relatively longer times required to crystallize the entire PCM storage element as compared to the time necessary to RESET the PCM storage element.

It would be helpful to provide an apparatus and methods to provide a PCMS device that may be SET using only a fraction of the energy that would otherwise be necessary to SET the PCMS device. Use of an energy efficient memory device comprising PCMS and related methods would be helpful for use in electronic devices that use memory devices, particularly those electronic devices with a finite energy source such as battery operated stations including cell phones, mobile internet devices, netbooks, and other mobile devices.

One such method comprises writing (SET) a phase change memory with switch (PCMS) having an ovonic threshold switch (OTS) and a PCM storage element by using one or more low-energy SET pulses that do not crystallize a phase change material completely but create one or more crystalline filaments, conducting filaments, or partially crystallized regions in an otherwise amorphous volume. While this SET process may not necessarily reduce the resistance of the phase change material to levels observed in a conventional phase change memory (where no snap-back selector such as the OTS is present), it may reduce the threshold voltage of the phase change material sufficiently to enable a snap-back of the PCMS cell during a demarcation voltage read. Another method may comprise using a low-energy SET pulse to threshold an ovonic threshold switch (OTS) and write a phase change material in a PCM storage element of a phase change memory with switch (PCMS), wherein the PCM storage element comprises an amorphous volume after writing the phase change material, and using a demarcation voltage to read the PCMS.

Now turning to the figures, FIG. 1 illustrates an array of a PCMS **50** organized into bit lines **105** and word lines **110** according to an embodiment of the present invention. As shown in an embodiment of the present invention in FIG. 1, the PCMS comprises a phase change memory (PCM) element **20**, a heater element **15**, and a snapback selector or access element **10**. In an alternate embodiment, the PCMS does not include a heater element **15**.

The PCM storage element **20** includes a phase change material. In an embodiment of the present invention, the phase change material may include two properties: (a) it can exist locally in an amorphous phase without crystallization for a prolonged period of time, such as for several years, at room temperature, and (b) the amorphous phase can crystallize rapidly if temperature is raised to about 100 to 350 degrees Centigrade (C).

In general, a crystallization time of the phase change material decreases with increasing temperature. For example, if an amorphous PCM storage element **20** is heated up to ~150 C, it will crystallize within a minute or so. If the amorphous PCM is heated quickly up to ~200 C, it will crystallize within

a second. If the amorphous PCM is heated very quickly up to ~300 C, such as by a pulse, it will crystallize within a micro-second. Thus, the phase change material may remain stable locally in one of the two phases or in a combination of the two phases. For the phase change material, the crystalline phase is energetically more favorable (lower free energy) than the amorphous phase.

A large variety of phase change material types with widely differing properties may be selected for the PCM storage element **20**. The phase change material may include a stoichiometric or a non-stoichiometric compound. The phase change material may include a eutectic or a peritectic material. The phase change material may include a single-phase or multiphase materials. The phase change material may be doped with various elements. In an embodiment of the present invention, the phase change material may have a binary composition, a ternary composition, or a quaternary composition. In another embodiment of the present invention, the phase change material may have a pseudo-binary composition.

The phase change material is called a chalcogenide alloy if it includes at least one element from Group VI A of the periodic table. Some phase change materials include elements from Group III A, Group V A, and Group VI A. Examples include GaSbTe and InSbTe. Other phase change materials include elements from Group IV A, Group V A, and Group VI A. Group III A of the periodic table includes elements such as gallium and indium. Group IV A of the periodic table includes elements such as silicon, germanium, and tin. Group V A of the periodic table includes elements such as phosphorus, arsenic, antimony, and bismuth. Group VI A of the periodic table includes elements such as sulfur, selenium, and tellurium.

In an embodiment of the present invention, the phase change material may include one or more elements from Group I B of the periodic table, such as silver or gold. In another embodiment of the present invention, the phase change material may also include one or more elements from Group VIII B of the periodic table, such as cobalt or palladium.

FIG. 2 shows a graph of log current vs. voltage for a snapback selector or access element **10**, such as an ovonic threshold switch (OTS). Starting with a high electrical resistance (RESET) state at a low electric field, the current in the access element **10** increases **205** with increasing voltage with a very small current until a threshold voltage $V_{TH\ OTS}$ is reached.

After a snapback **210**, a highly conductive dynamic ON state **215** is maintained in the access element **10** as long as a current higher than a holding current $I_{H\ OTS}$ is flowing through the access element **10**. This transient high-conductivity state is electronic in origin and does not involve any phase change in the access element **10**.

When the threshold voltage $V_{TH\ OTS}$ of the access element **10** is exceeded, the access element **10** switches from the OFF state to the ON state and allows current to flow through the phase change material storage element **20** that is connected in series to the access element **10**. In the ON state, the voltage potential across the access element **10** remains close to a holding voltage ($V_{H,OTS}$) as the current flowing through the access element **10** increases.

The access element **10** may remain in the ON state until the current through the access element **10** drops below a holding current ($I_{H\ OTS}$). Below this value, the access element **10** may return to a high-resistance, non-conductive OFF state until the $V_{TH\ OTS}$ or $I_{H\ OTS}$ is exceeded again. Whenever directed,

the access element **10** may repeatedly and reversibly switch between the OFF state and the ON state, but it does not crystallize.

The PCMS **50** has a single-level cell (SLC) if only 1 bit of data is stored in the PCMS **50**. The data values corresponding to the 2 logical states in each PCMS **50** include '1' and '0'. Thus, the phase change material in the PCM storage element **20** may be written (programmed) from one distinct memory state, such as a RESET state, to another distinct memory state, such as a SET state.

FIG. 3 shows a graph of log current vs. voltage for a single PCM storage element **20** which does not have a snapback selector or access element **10** connected in series. Starting with a high electrical resistance (RESET) state at a low electric field, the current **305** in the PCM storage element **20** remains small, but increases non-linearly as the voltage increases until a threshold voltage $V_{TH,PCM}$ for the phase change material is reached.

After a voltage snapback **310**, a highly conductive dynamic ON state **315** is maintained in the PCM storage element **20** as long as a current higher than a holding current $I_{H,PCM}$ is flowing through the PCM storage element **20**.

In contrast to the PCM configuration described above, embodiments of the invention use a PCMS **50** configuration as shown in FIG. 1. The PCMS **50** configuration differs from the PCM configuration in that the PCMS **50** configuration includes a memory cell **5** which has a phase change memory (PCM) storage element **20** and a snapback selector or access element **10**, otherwise referred to as the ovonic threshold switch (OTS).

Like the phase change material in the storage element **20** of the memory cell **5**, the access element **10** also exhibits threshold switching. However, the access element **10** and the storage element **20** may include different types of materials with dissimilar threshold voltages V_{TH} and threshold currents I_{TH} . Embodiments of the invention are associated with threshold switching and snapback behavior exhibited by the access element **10**. Switching the access element **10** on and off can control access to the storage element **20** in the memory cell **5**.

An easy glass former material is chosen for the access element **10** so that crystallization is extremely sluggish. In an absence of voltage and current, the access element **10** is amorphous at room temperature. The degree of crystallization of the access element **10** upon heating and application of a voltage and/or current is negligible. Unlike the phase change material in the storage element **20** of the memory cell **5**, the access element **10** returns to an amorphous state after the voltage and current are turned off.

As shown in FIG. 1, an array of the memory cells **5** in the PCMS **50** may be organized into columns of bit lines **105** and rows of word lines **205**. The bit line **105** and the word line **205** include conductors that are formed from a conductive material, such as copper. In different embodiments of the invention, a logical arrangement or a physical placement of the features in the PCMS **50** may vary in a layout. The memory cell **5** may optionally include a heater element **15** adjacent to and in thermal contact with the PCM storage element **20**. The heater element **15** (when present) may have a topology of a lance or a micro-trench (not shown).

The heater element **15** further includes a conductor that is formed from a conductive material. The conductive material may include titanium (Ti), titanium nitride (TiN), titanium tungsten (TiW), carbon (C), silicon carbide (SiC), titanium aluminum nitride (TiAlN), titanium silicon nitride (TiSiN), polycrystalline silicon, or tantalum nitride (TaN), among others.

The access element **10** may be located towards the bit line **105** side of the storage element **20** (as shown in FIG. **1**) or towards the word line **205** side of the storage element **20** (not shown). However, the access element **10** is not located between the heater **15** (when present) and the storage element **20**.

After the access element **10** turns on, a current will flow through the heater element **15** (when present) that is connected in series. The heater element **15** (when present) is a resistive element that transfers heat, such as through Joule heating, to the storage element **20** during a SET or RESET write pulse or pulses. If the heater element **15** is not present, Joule heating occurs mostly in the storage element **20**.

A particular combination of the bit line **105** and the word line **205** in the array may be addressed to access the memory cell **5**. After selecting the memory cell **5** coupled to the bit line **105** and the word line **205**, a voltage potential is applied to read or write the storage element **20** in the memory cell **5**. During a read operation for the PCMS **50**, a demarcation point voltage is applied to the memory cell **5** to interrogate a state of the phase change material in the storage element **20**. If the memory cell **5** is in a SET state, then the memory cell **5** thresholds and current is sensed through a sensing circuit. However, if the memory cell **5** is in a RESET state, then there is no threshold and no current is sensed through the sensing circuit. Certain features of device architecture for the PCMS **50** have not been shown in FIG. **1** to avoid obscuring the present invention. Examples of some features that may not be shown include transistor circuits that serve as current sources, pulse generators, sense amplifiers, and voltage pre-chargers.

Once the OTS **10** and the PCM storage element **20** are connected in series, a combined threshold voltage $V_{TH\ PCM}$ of the PCMS **50** is established. If the PCM storage element **20** in the PCMS **50** is completely crystalline, $V_{TH\ PCM}$ is zero or substantially zero, so that $V_{TH\ OTS}$ of the access element must be equal to $V_{TH\ PCMS}$. As shown in FIG. **4**, embodiments of the invention envision an energy-efficient write process to SET the phase change material in the storage element **20** of the PCMS **50**. According to embodiments of the invention, one or more low-energy pulses may be used in the write (SET) process. Sufficient SET-to-RESET and RESET-to-SET statistics for a specific PCMS **50** technology are collected and used to determine an optimal profile for current (amplitude) vs. time (pulse width) for the write (SET) process in the present invention. This will accommodate variability in the PCM storage element **20**, including the phase change material, in the memory cell **5** of the PCMS **50**.

When the PCMS **50** configuration is used, the phase change material in the PCM storage element **20** does not need to be completely SET to $V_{TH\ PCM}=0$ as in conventional PCM-only memories. A completely crystalline phase change material has $V_{TH\ PCM}=0$, while an amorphous phase change material has $V_{TH\ PCM}=1-4$ V depending upon the composition of the phase change material and the geometry of the memory cell **5**. A threshold voltage of $V_{TH\ PCM}=0$ in a completely crystalline phase change material would correspond to a voltage drop V_{PCM} across the PCM storage element **20** (at a current level equal to $I_{TH\ OTS}$) of $V_{PCM}@I_{TH\ OTS}=0.001$ V (assuming $I_{TH\ OTS}=1$ μ A and a SET resistance of 1 kOhm in the PCM storage element **20**, as an illustrative example). In the PCMS configuration, however, the phase change material may be SET to a state in which $V_{PCM}@I_{TH\ OTS}<0.4$ V (wherein V_{PCM} is voltage **470** in FIG. **4** and FIG. **5**), for which the corresponding PCMS current-voltage curve is **405**. The PCMS **50** may be configured to have a first circuit to write a SET state for the PCMS **50** and a second circuit to write a RESET state for the PCMS **50** wherein the first circuit is a

lower current circuit than the second circuit. Alternately, the same circuit may be used to write the SET state and the RESET state for the PCMS **50**.

As shown in FIG. **7**, creating a conducting filament **705**, which may be a crystallized filament in an amorphous volume **710** of the PCM storage element **20** comprising a crystalline volume **715**, the amorphous volume **710**, and the conducting filament **705** allows a SET pulse or pulses of much lower energy than for a conventional SET pulse that crystallizes the phase change material of the PCM storage element **20** completely to $V_{TH\ PCM}=0$. Further according to embodiments of the invention, an amplitude of a SET pulse current is 10-15% or less than an amplitude of a RESET pulse current. In another embodiment, the amplitude of the SET pulse current is approximately 1% of the RESET pulse.

In embodiments of the invention as shown in FIG. **7**, the conducting filament **705** extends from the heater element **15** through the amorphous volume **710** to the crystalline volume **715** of the PCM storage element **20**. Although $V_{PCM}@I_{TH\ OTS}$ drops significantly to 0.4 V, an electrical resistance of the phase change material may not drop as much from its original RESET resistance value and may therefore still be quite high, such as 10-100 times the minimum SET resistance for a completely crystalline cell. A low-energy SET pulse or pulses may not be able to obtain sufficient resistance contrast in PCM-only memories, in which the resistance is measured to determine the state of the cell.

$V_{PCM}@I_{TH\ OTS}$ drops to 0.4 V or less easily due to the conducting filament **705**, but the resistance does not drop as quickly. The 0.4 V is used as an illustrative example for a voltage drop **470** that is low compared to $V_{TH\ PCM}=1-4$ V in the RESET state of the phase change material. Other values of the voltage drop **470** may be selected from a range of 0.1-0.5 V.

FIG. **5** shows a graph of log voltage vs. current for two different phase change materials; a first phase change material **510** and a second phase change material **520**, without a switch such as an OTS. In both cases, the phase change material has been preconditioned to an (amorphous) RESET state before a current amplitude (horizontal axis) is applied. The vertical axis shows the voltage drop V_{PCM} across the PCM storage element **20** at a fixed given current $I_{TH\ OTS}$, which may represent the threshold current of OTS (though OTS is not present in this example), and which may be 1 μ A for example. The phase change material **510** has a steeper SET curve and may be a more suitable candidate material for the storage element **20** than the phase change material **520** because a lower current is required to program the material to a state in which $V_{PCM}@I_{TH\ OTS}<0.4$ V (voltage drop **470**) in a PCMS cell that does include OTS. The two phase change materials may share a similar RESET curve **530**.

In the read process, a demarcation voltage needs to be slightly higher, such as by a voltage drop **470**, than $V_{TH\ OTS}$. Once the access element **10** snapback occurs in a read process, the voltage is transferred from the access element **10** to the PCM storage element **20** due to a parasitic resistance capacitance product RC that is associated with connectivity of the two terminals of the memory cell **5**.

In a demarcation read process, if the transferred voltage minus a voltage drop **470**, such as 0.4 V, at the phase change material (which does not need to be provided any further by the transfer) is larger than the threshold voltage $V_{TH\ PCM}$ of the PCM storage element **20**, then the PCM storage element **20** in the memory cell **5** will also undergo a triggered electronic threshold switching and snap back **410** just as the access element **10** had already snapped back earlier. Thus, the

access element **10** serves as an amplifier and the voltage drop of the access element **10** drops on the PCM.

With this demarcation read mechanism, if the PCM storage element **20** in the memory cell **5** has a threshold voltage less than a sum of the snapback voltage **210** and a voltage drop **470**, when the demarcation voltage is greater than a sum of the OTS **10** threshold voltage and a voltage drop **470**, of the storage element **20** with the current equal to OTS **10** threshold current, then the phase change material in the memory cell **5** will snap back.

In the above example, for a single memory cell, a demarcation read voltage within the voltage range **450** may be used (FIG. **4**). In an embodiment of the present invention, the voltage range **450** is 2-4 V wide.

FIG. **6** shows a cumulative probability plot vs. threshold voltage for an array of PCMS **50** memory cells **5**. The line denoted as **200** represents the distribution of threshold voltages in the SET state of the PCMS **50** (completely crystalline, therefore being equal to the threshold voltage of OTS), and the line denoted as **300** represents the distribution of threshold voltages in the RESET state of the PCMS **50**. In an array of memory cells **5**, the read demarcation voltage must be located within the voltage range **630** and must therefore be higher by a voltage drop **470**, such as 0.4 V, than the PCMS **50** memory cell **5** with the highest OTS threshold voltage **610**. Also, the read demarcation voltage must be lower than the PCMS **50** memory cell **5** with the lowest RESET threshold voltage **620**.

Therefore, in contrast to a conventional resistance read scheme for phase change memory which requires a complete crystallization of the phase change material, the SET resistance requirement for the voltage demarcation point read can be relaxed. The memory cell **5** need not be programmed to a low resistance state as would otherwise have been required for a conventional scheme to read resistance. The resistance of the states **540** and **550**, as shown in FIG. **5**, may still be quite high, such as 10-100 times the minimum SET resistance for a completely crystalline phase change material.

As a result, the relaxed SET requirement allows use of a lower SET energy through use of a low-energy SET pulse or pulses for the SET write operation since the phase change material does not need to be completely crystallized, using a SET method combined with the PCMS **50** configuration (i.e., when an access element **10** that exhibits threshold switching, such as an OTS is present) without reduction of read window size or signal-to-noise ratio. In the conventional read scheme for PCM-only memories, this SET method would increase the SET resistance, such as by a factor of 10-100, compared to the completely crystalline SET state, and therefore significantly reduce read window size and signal to noise ratio. Thus the SET to RESET energy ratio need not be as high as 100:1 or even 10:1 and may approach 1:1. For example, the SET current may be 10 to 20x lower than in a PCM-only memory for which the access element **10** is not used.

Using such a read mechanism, the SET current amplitude can be as low as 1% of the RESET current and would not need to be higher than at most 10-15% of the RESET current. As an example, if the RESET current is around 1.5 mA, the memory cell **5** may be SET with about 15 uA current since SET only creates a conductive filament in the amorphous volume of the storage element **20**, wherein the conductive filament may be a crystalline filament or a partially crystalline filament.

The RESET current depends on the architecture and the size of the memory cell **5**. For example, the RESET current could be considerably lower than 1.5 mA, such as 0.2 mA, for a much smaller cell or a different architecture (not shown). However, the SET amplitude would then decrease proportionately so that 0.5%-20% of the RESET current would still

be sufficient to crystallize the conductive filament in the amorphous volume of the storage element **20**.

A duration of current flow depends on (a) thermal conductivity of the access element **10**, the phase change material (in the storage element **20**), the heater **15** (if present), and the surrounding materials, (b) the shape and size of the amorphous volume (in the bit), and (c) the device architecture (logical and physical layout) of the PCMS **50**.

In an embodiment of the present invention, a SET pulse width (duration of current flow) is about 250-500 nsec. In another embodiment of the present invention, a SET pulse width is about 125-250 nsec. In a further embodiment of the present invention, the SET pulse width is about 45-125 nsec. In yet another embodiment of the present invention, the SET pulse width is about 10-45 nsec. In some phase change materials, a necessary pulse width may be as high as 500 ns, but the pulse amplitude is very low so a desired low energy or power may still be achieved.

Characteristics similar to the access element **10** may apply to a thyristor based selector such as SCR or DIAC. In an embodiment of the present invention, the access element **10** includes a thyristor (not shown). The thyristor has an anode, a cathode, and a gate. The two transistors in the thyristor feed each other (through their respective base currents), so the thyristor operates as a complementary regenerative switch.

After being turned on, the thyristor remains conducting even if a voltage applied (through the word line) to the gate is removed. Thus, the thyristor can be triggered, or activated, by a short pulse to the gate, but the voltage signal from the word line need not remain high during an entire access time. The thyristors for the non-selected bit lines do not conduct since they are effectively shorted out. Furthermore, any leakage through the non-selected bit lines is greatly reduced.

As appropriate, the thyristor may be turned off, or deactivated, by reducing voltage below a predetermined minimum holding voltage, such as by shorting out the anode and the cathode, such as by bringing the bit line (coupled to the anode) down to the voltage of the source line (coupled to the cathode), which may be ground in one embodiment of the present invention.

If an anode-to-cathode voltage, such as a bit line-to-source line voltage, is kept low, such as below 2 volts, the thyristor acts as an open circuit and isolates the storage element electrically. However, if the bit line voltage is raised, such as substantially more than 2 volts, above the source line voltage, the thyristor breaks down, the voltage snaps back, the thyristor becomes activated, and the thyristor conducts. When the thyristor is conducting, the associated storage element becomes electrically coupled to the bit line and is available for access, such as for a program (write) or read operation.

In another embodiment of the invention, the access element **10** includes a semiconductor-controlled rectifier (SCR) with a 4-layer configuration, such as a vertically-oriented pnpn structure formed on a substrate (not shown).

In still another embodiment of the present invention, the access element **10** includes a pair of SCRs sharing a laterally-oriented pnpn structure formed in a substrate (not shown).

An amorphous volume in the phase change material in the RESET state is shown as an amorphous hemisphere or dome in FIG. **7**. Alternatively, other topologies may be used for the amorphous volume in the storage element **20**. For example, depending on the device architecture of the PCMS **50**, the amorphous volume may include an amorphous line (not shown) or an amorphous bridge (not shown). Further, in another embodiment the heater element **15** may not be present. Also, other embodiments may even use a complete

amorphization of the PCM storage element **20** in a RESET process, leaving substantially no crystalline volume remaining.

In an embodiment of the invention as shown in FIG. 7, the energy-efficient write pulse or pulses form conductive filaments **705** within the amorphous volume **710**, such as amorphous dome, of the PCMS **50**. The conductive filament **705** may be crystalline. It may or may not be formed by merging together a series of adjacent small localized crystal nucleation centers inside the amorphous dome. The PCM storage element **20** may be located directly adjacent to and in electrical contact with other electrode materials (not shown).

A SET current of 15 μA or more may be higher than the threshold current of the PCM storage element **20** or the access element **10**, which is typically between 0.1 μA and 10 μA in both cases. Therefore, both the PCM storage element **20** and the access element **10** are in the on-state during the SET pulse (WRITE). If the PCM storage element **20** is in the on-state, a highly-conducting filament may already exist which would then remain conductive (or become crystalline) when the SET pulse is switched off.

As shown in FIG. 7, although the amorphous volume **710** or dome may remain almost the same size, the conductive filament eventually extends completely through the amorphous volume **710** or dome and allows a current to flow. Forming conductive filaments reduces threshold voltage of the phase change material but may not necessarily reduce resistance to a level required for conventional resistance-based read schemes used for the phase change material. In order to reduce $V_{PCM}@I_{TH\ OTS}$ down to 0.4 V in the PCM storage element **20**, a conducting filament **705**, such as a crystalline filament or partially crystallized region must extend from the heater **15** (when present) completely through the amorphous dome **710**, outside of which the phase change material is always crystalline.

FIG. 8 illustrates a block diagram of an electronic device comprising various embodiments of the invention. The electronic device **800** may include one or more host processors or central processing unit(s) (CPUs) **802** (which may be collectively referred to herein as "processors **802**" or more generally "processor **802**") coupled to an interconnection network or bus **804**. The processors **802** may be any type of processor such as a general purpose processor, a network processor (which may process data communicated over a computer network), etc. (including a reduced instruction set computer (RISC) processor or a complex instruction set computer (CISC)). Moreover, the processors **802** may have a single or multiple core design. The processors **802** with a multiple core design may integrate different types of processor cores on the same integrated circuit (IC) die. Also, the processors **802** with a multiple core design may be implemented as symmetrical or asymmetrical multiprocessors.

The processor **802** may include one or more caches **803**, which may be private and/or shared in various embodiments. Generally, a cache **803** stores data corresponding to original data stored elsewhere or computed earlier. To reduce memory access latency, once data is stored in a cache **803**, future use may be made by accessing a cached copy rather than refetching or recomputing the original data. In various embodiments, the cache **803** comprises the PCMS **50** of FIG. 1.

A chipset **806** may additionally be coupled to the interconnection network **804**. The chipset **806** may include a memory control hub (MCH) **808**. Alternately, the processor **802** and the MCH **808** may be combined to form a single chip. The MCH **808** may include a memory controller **810** that is coupled to a memory **812**. The memory **812** may store data, e.g., including sequences of instructions that are executed by

the processor **802**, or any other device in communication with components of the electronic device **800**. In various embodiments, the memory **812** includes one or more volatile storage or non-volatile memory devices such as the PCMS **50** of FIG. 1.

The memory **812** may include one or more of the following in various embodiments: an operating system (O/S) **832**, application **834**, device driver **836**, buffers **838**, function driver **840**, and/or protocol driver **842**. The processor(s) **802** executes various commands and processes one or more packets with one or more computing devices coupled to the network **845** over a radio **862**.

In various embodiments, the application **834** may utilize the O/S **832** to communicate with various components of the electronic system **800**, e.g., through the device driver **836** and/or function driver **840**.

As illustrated in FIG. 8, the communication device **830** includes a first network protocol layer **850** and a second network protocol layer **852** for implementing the physical (PHY) layer to send and receive network packets to and from a base station, an access point, and/or other stations (not shown) over the radio **862**. The communication device **830** may further include a direct memory access (DMA) engine **854**, which may write packet data to buffers **838** to transmit and/or receive data. Additionally, the electronic device **800** may include a controller **856**, which may include logic, such as a programmable processor for example, to perform communication device related operations. In various embodiments, the controller **856** may be a MAC (media access control) component. The communication device **830** may further include a memory **858** of any type of volatile/nonvolatile memory devices comprising the PCMS **50** of FIG. 1.

In various embodiments, the communication device **830** may include a firmware storage device **860** to store firmware (or software) that may be utilized in management of various functions performed by components of the communication device **830**. The storage device **860** may be any type of a storage device such as a non-volatile storage device comprising the PCMS **50** of FIG. 1.

Many embodiments and numerous details have been set forth above in order to provide a thorough understanding of the present invention. One skilled in the art will appreciate that many of the features in one embodiment are equally applicable to other embodiments. One skilled in the art will also appreciate the ability to make various equivalent substitutions for those specific materials, processes, dimensions, concentrations, etc. described herein. It is to be understood that the detailed description of the present invention should be taken as illustrative and not limiting, wherein the scope of the present invention should be determined by the claims that follow.

We claim:

1. A method comprising:

using a low-energy SET pulse to threshold an access device and write a phase change material in a PCM storage element of a phase change memory with switch (PCMS), wherein the low-energy SET pulse comprises a SET current that is significantly lower than that used for a phase change memory based on a resistive read scheme, wherein the PCM storage element comprises an amorphous volume after writing the phase change material, and wherein the low-energy SET pulse reduces a threshold voltage of the phase change material to enable a snap-back of a PCMS cell; and
using a demarcation voltage to read the PCMS, wherein the low-energy SET pulse does not reduce an electrical

11

resistance of the phase change material to a level involved with the resistive read scheme;
 wherein an electrical resistance of a SET state is 10-100 times higher than an electrical resistance of a SET state in a phase change memory based on the resistive read scheme.

2. The method of claim 1 wherein an OTS and the storage element are connected in series.

3. The method of claim 1 wherein the access device is an OTS that does not change phase.

4. The method of claim 1 wherein an amplitude of a SET pulse current is 15% or less of an amplitude of a RESET pulse current.

5. The method of claim 4 wherein the SET pulse current forms a conducting filament in the amorphous volume of the phase change material.

6. The method of claim 1 further comprising using a plurality of SET pulses to write the phase change material in the PCM storage element.

7. A phase change memory with switch (PCMS) comprising:

a memory cell, the memory cell comprising an access device and a phase change memory (PCM) storage element, the PCM storage element comprising an amorphous volume, a crystalline volume, and a conducting filament in the amorphous volume, wherein the conducting filament extends through the amorphous volume and connects to the crystalline volume; and

a source to apply a read demarcation voltage or current to the storage element, wherein an electrical resistance of the PCM storage element in a SET state is about 10 to about 100 times higher than an electrical resistance of a SET state in a phase change memory based on a resistive read scheme.

8. The phase change memory with switch of claim 7, wherein the read demarcation voltage is sufficient to threshold the access device.

9. The phase change memory with switch of claim 7, further comprising a heater element, wherein the conducting filament connects the heater element to the crystalline volume.

12

10. The phase change memory with switch of claim 7, wherein the electrical resistance of the PCM storage element in the SET state is higher than a PCM storage element that is substantially crystalline.

11. The phase change memory with switch of claim 7, further comprising a first circuit to write the SET state for the PCMS and a second circuit to write a RESET state for the PCMS.

12. The phase change memory with switch of claim 11, wherein the first circuit is a lower current circuit than the second circuit.

13. A system comprising:

a processor; and

a phase change memory with switch (PCMS), wherein the PCMS comprises:

an access device; and

a phase change memory (PCM) storage element connected in series to the access device, wherein the PCM storage element comprises an amorphous volume, a crystalline volume, and a conducting filament in the amorphous volume, wherein the conducting filament extends through the amorphous volume and connects to the crystalline volume, and wherein an electrical resistance of the PCM storage element in a SET state is about 10 to about 100 times higher than an electrical resistance of a SET state in a phase change memory based on a resistive read scheme.

14. The system of claim 13, wherein a read voltage is sufficient to threshold the OTS.

15. The system of claim 13, further comprising a heater element, wherein the conducting filament connects the heater element to the crystalline volume.

16. The system of claim 13, wherein the electrical resistance of the PCM storage element in the SET state is higher than a PCM storage element that is substantially crystalline.

17. The system of claim 13, further comprising a first circuit to write the SET state for the PCMS and a second circuit to write a RESET state for the PCMS.

* * * * *